



# SPEED-PACK II

For High-Speed Packaging

260-570 tons



## Hong Kong

Unit 2001,20th Floor,Citicorp Centre,18 Whitfield Road,Hong Kong

Tel: +852 2665 3222

Website: [www.chenhsong.com](http://www.chenhsong.com)

Email: [marketing@chenhsong.com](mailto:marketing@chenhsong.com)

202307

## About Chen Hsong

Chen Hsong, established in 1958, is one of the largest manufacturers of injection moulding machines in the world, with annual sales exceeding 20,000 sets.

For over 60 years, Chen Hsong sold to more than 85 countries across the globe, supplying injection moulding machines with clamping force from 20 tons to 6,500 tons. In 1991, Chen Hsong became listed on the Hong Kong Stock Exchange (stock code: 0057).

Headquartered in Hong Kong, Chen Hsong operates numerous manufacturing and research facilities in China, including Shenzhen, Shunde, Ningbo and Taiwan, as well as in Japan.

**65 Years of Excellence**  
Since 1958

**20,000 sets / year**  
One of the largest in the world

**Operates 800,000 sqm of facilities**  
Global Presence

**24 hours**  
Hundred-strong, round-the-clock service team



## One-Stop Solution From Tools to Full Production Lines



Provides full-range automation solutions that integrate the injection moulding machines, tools, robots, material feeding, stacking, inspection and packaging equipment.

## SPEED-PACK II

### High Speed, High Stability, High Precision – All At The Same Time

Chen Hsong develops the revolutionary SPEED-PACK series of packaging machines based on its highly-popular SPEED series of high-speed injection moulding machines. Its secret lies with Chen Hsong's remarkable Precision Hydraulics™ technology (developed in Japan) that enables extremely high speed, but silky-smooth, mechanical motion while maintaining superb sub-millimeter precision.

In other words, the SPEED-PACK is tailor-made for packaging.

Exclusive Precision Hydraulics™ technology endows the SPEED-PACK II with performance close to high-end Japanese hydraulic offerings. Exceptional speed, stability, repeatability and precision are all in a different league from competition offerings. Case in point: a complete dry clamping cycle requires only 1.5 seconds, while achieving 500mm/s on injection.



### High Efficiency Specialty Screw

Superior melt quality and plasticising speed

Standard for the SPEED-PACK II is a screw specially designed for high-speed and high-quality plasticising needs of the packaging industry, with 50% higher injection speed, higher injection pressure and enhanced precision all round.

### Very Strong Machine Base

Machine base is rock-solid stable, ensuring the highest yield possible even for difficult products

Designed to match the unique requirements of ultra-high-speed motion curves, the machine base is specially designed to enhance structural strength, rigidity and stability by 50%, thus ensuring the highest part quality. Lowered center of gravity of the machine gives much smoother, stable and mechanical movements.

### Very Thick (And Strong) Platen

Minimal platen and toggle deformations

Optimised platen design distributes stresses evenly for higher part quality

### Perfect Alignment

Even stress distribution helps eliminate rejects

Stress is channelled through the centre of the moving platen before distributing outwards evenly. Advanced Japanese mechanical design guarantees perfect alignment of the four corners at all moments, effectively eliminating flashes.

### Balanced Dual Hydraulic Cylinders and Linear Guide Rails

Low friction mechanism for high precision injection control

Non-contact potentiometers for the highest accuracy during high-speed injection; Eliminates wear and interferences for ultimate stability.

### Ultra High Speed, High Precision, Fast Responses

Top-of-the-line high-response servomotor with 2x faster dynamic responses

Faster responses for higher repeatability, control precision and energy efficiency.

A power pack that is 30% larger for much higher production efficiency.

**Precision  
Hydraulics™**

**500** mm/s  
Maximum injection speed

## Always a model that fits your precise needs

A machine that fits all your diverse needs

# 260

ton

### SPEED-PACK II 260

Machine dimensions (L\*W\*H)  
6.08\*1.70\*1.84m  
Space between tie-bars (H\*V)  
580x580mm



### SPEED-PACK II 330

Machine dimensions (L\*W\*H)  
7.16\*1.78\*2.00m  
Space between tie-bars (H\*V)  
670x670mm



### SPEED-PACK II 400

Machine dimensions (L\*W\*H)  
8.02\*1.93\*2.05m  
Space between tie-bars (H\*V)  
720x720mm



### SPEED-PACK II 470

Machine dimensions (L\*W\*H)  
8.78\*2.03\*2.10m  
Space between tie-bars (H\*V)  
820x820mm



### SPEED-PACK II 570

Machine dimensions (L\*W\*H)  
8.94\*1.90\*1.98m  
Space between tie-bars (H\*V)  
850x850mm



# 570

ton

## Details – Always the Details

Secrets to the SPEED-PACK II's superior performance



### Precision Hydraulics™

Developed by high-end Japanese hydraulic experts, Precision Hydraulics™ technology optimises the entire hydraulic circuit, removing kinks and shocks, ensuring fine-tuned hydraulic oil control in order to achieve silky-smooth and highly-repeatable mechanical motion.

Third-party tests have repeatedly shown that an injection moulding machine equipped with Precision Hydraulics™ performs close to high-end Japanese hydraulic offerings.

When Precision Hydraulics™ is used to drive a custom-designed, ultra-high-response servosystem, and controlled by an advanced, high-end, high-response intelligent computer controller close-looping over a high-speed digital bus, the result is unbelievable precision, stability and repeatability that are exactly the hallmarks of the SPEED-PACK II.



### Advanced high-response computer controller

- 1 Complies with JIS and IEC testing standards
- 2 Named-brand high-definition 10" TFT color LED
- 3 Integrated EtherCAT high-speed bus system
- 4 LED backlight with high brightness and long life
- 5 Advanced SMT technology with highest stability and reliability
- 6 Multiple languages
- 7 Intelligent fault diagnostics
- 8 Online operational instructions
- 9 Industrie 4.0 interface

# SPEED-PACK II 260

## Specifications

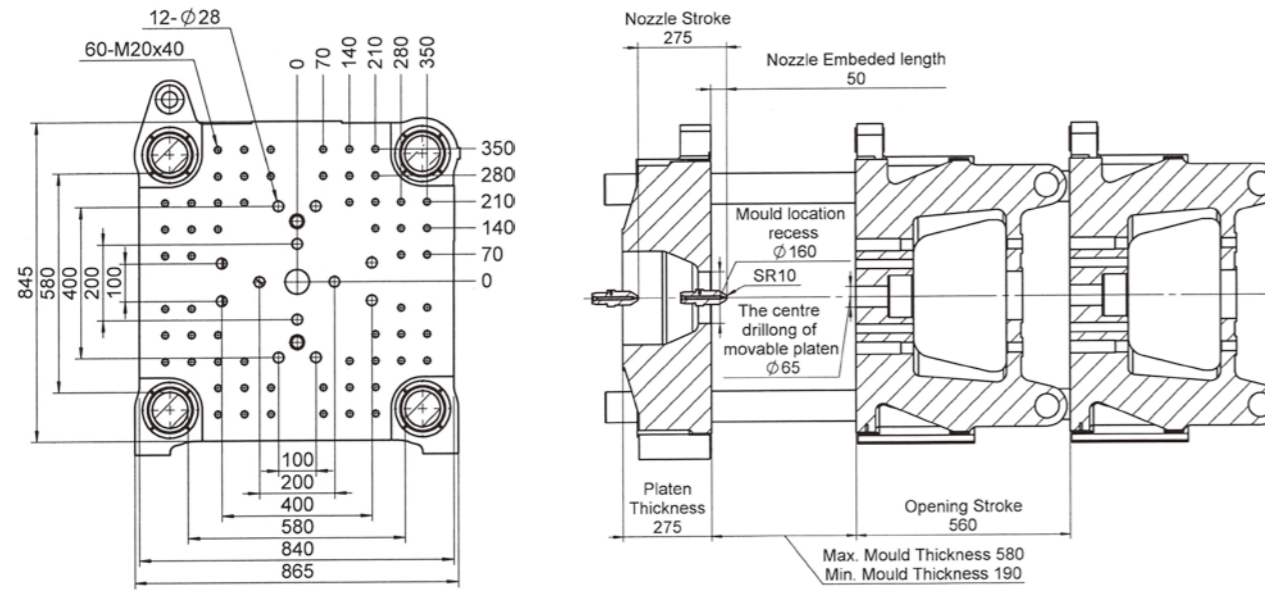

INJECTION UNIT		A	B	CLAMPING UNIT	
Screw Diameter	mm	31	36	Clamping Force (Max.)	ton 260
Screw L/D Ratio	L/D	24.4	21.0	Opening Stroke	mm 560
Screw Stroke	mm	180		Space Between Tie Bar(H*V)	mm 570x570
Swept Volume	cm <sup>3</sup>	136	183	Mould Thickness(Min-Max)	mm 190-580
Shot Weight (PS)	g	124	167	Ejector Force	ton 6.7
Shot Weight (PS)	oz	4.4	5.9	Ejector Stroke	mm 120
Injection Pressure (Max.)	kgf/cm <sup>2</sup>	2549	1890	Mould Register Hole	mm 100
Injection Rate	cm <sup>3</sup> /s	340	458	POWER/HEATING UNIT	
Injection Speed (Max.)	mm/s	450		System Pressure	kgf/cm <sup>2</sup> 175
Screw Rotation Speed (Max.)	rpm	300		Motor Power	kW 40
Screw Nozzle Force	ton	4.2		Electrical Heating Power	kW 8.07
Nozzle Stroke	mm	275		Barrel Heating Zones	3+1

### OTHERS

Machine Dimensions	m	6.08x1.70x1.84
Oil Tank Capacity	L	330
Machine Weight (Approx)	ton	7.5

# SPEED-PACK II 330

## Specifications

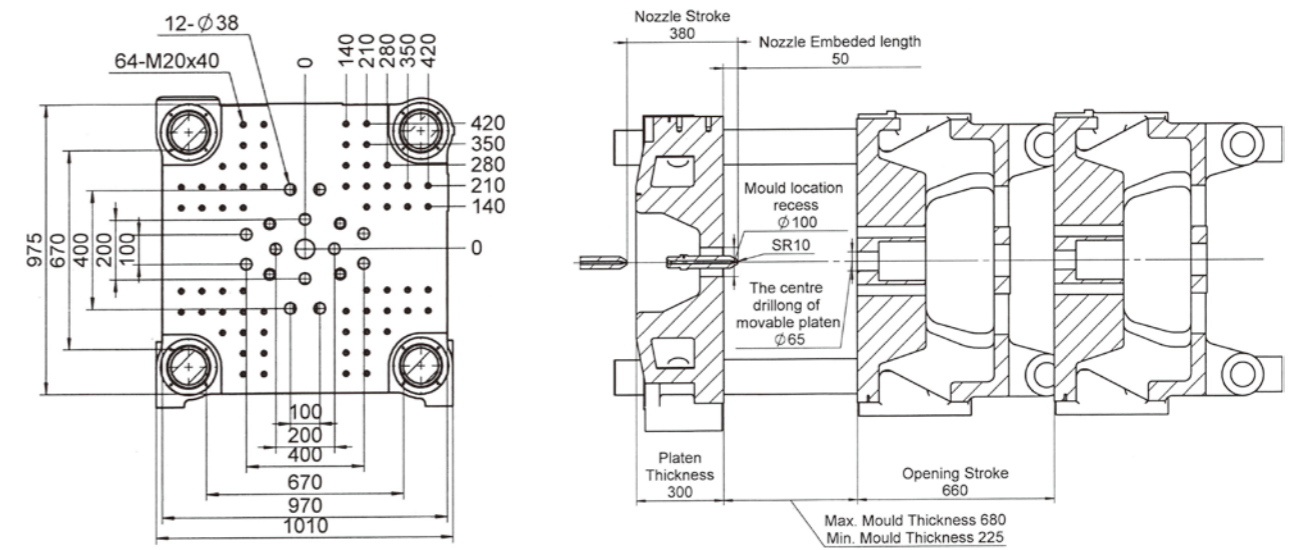

INJECTION UNIT		A	B	CLAMPING UNIT	
Screw Diameter	mm	46	52	Clamping Force (Max.)	ton 330
Screw L/D Ratio	L/D	26	26	Opening Stroke	mm 660
Screw Stroke	mm	260		Space Between Tie Bar(H*V)	mm 670x670
Swept Volume	cm <sup>3</sup>	432	552	Mould Thickness(Min-Max)	mm 225-680
Shot Weight (PS)	g	393	502	Ejector Force	ton 11.1
Shot Weight (PS)	oz	13.9	17.7	Ejector Stroke	mm 100
Injection Pressure (Max.)	kgf/cm <sup>2</sup>	2084	1631	Mould Register Hole	mm 100
Injection Rate	cm <sup>3</sup> /s	869	1111	POWER/HEATING UNIT	
Injection Speed (Max.)	mm/s	500		System Pressure	kgf/cm <sup>2</sup> 175
Screw Rotation Speed (Max.)	rpm	300		Motor Power	kW 40+40
Screw Nozzle Force	ton	6.2		Electrical Heating Power	kW 21.75
Nozzle Stroke	mm	380		Barrel Heating Zones	4+1

### OTHERS

Machine Dimensions	m	7.4x1.8x2.0
Oil Tank Capacity	L	700
Machine Weight (Approx)	ton	13.5

# SPEED-PACK II 400

## Specifications

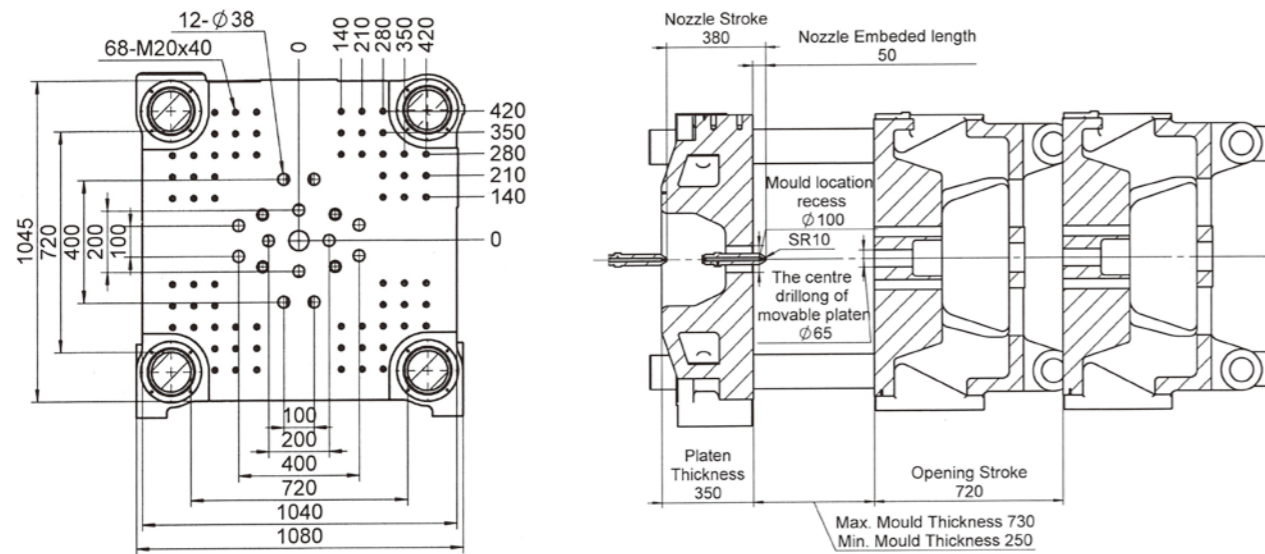

INJECTION UNIT		A	B	CLAMPING UNIT	
Screw Diameter	mm	52	60	Clamping Force (Max.)	ton 400
Screw L/D Ratio	L/D	26	26	Opening Stroke	mm 720
Screw Stroke	mm	260		Space Between Tie Bar(H*V)	mm 720x720
Swept Volume	cm <sup>3</sup>	552	735	Mould Thickness(Min-Max)	mm 250-730
Shot Weight (PS)	g	502	669	Ejector Force	ton 11.1
Shot Weight (PS)	oz	17.7	23.6	Ejector Stroke	mm 180
Injection Pressure (Max.)	kgf/cm <sup>2</sup>	1631	1225	Mould Register Hole	mm 100
Injection Rate	cm <sup>3</sup> /s	1316	1752	POWER/HEATING UNIT	
Injection Speed (Max.)	mm/s	500		System Pressure	kgf/cm <sup>2</sup> 175
Screw Rotation Speed (Max.)	rpm	300		Motor Power	kW 51+40
Screw Nozzle Force	ton	6.2		Electrical Heating Power	kW 25.05
Nozzle Stroke	mm	380		Barrel Heating Zones	4+1
OTHERS					
Machine Dimensions	m	8.02x1.93x2.05			
Oil Tank Capacity	L	760			
Machine Weight (Approx)	ton	15.8			

# SPEED-PACK II 470

## Specifications

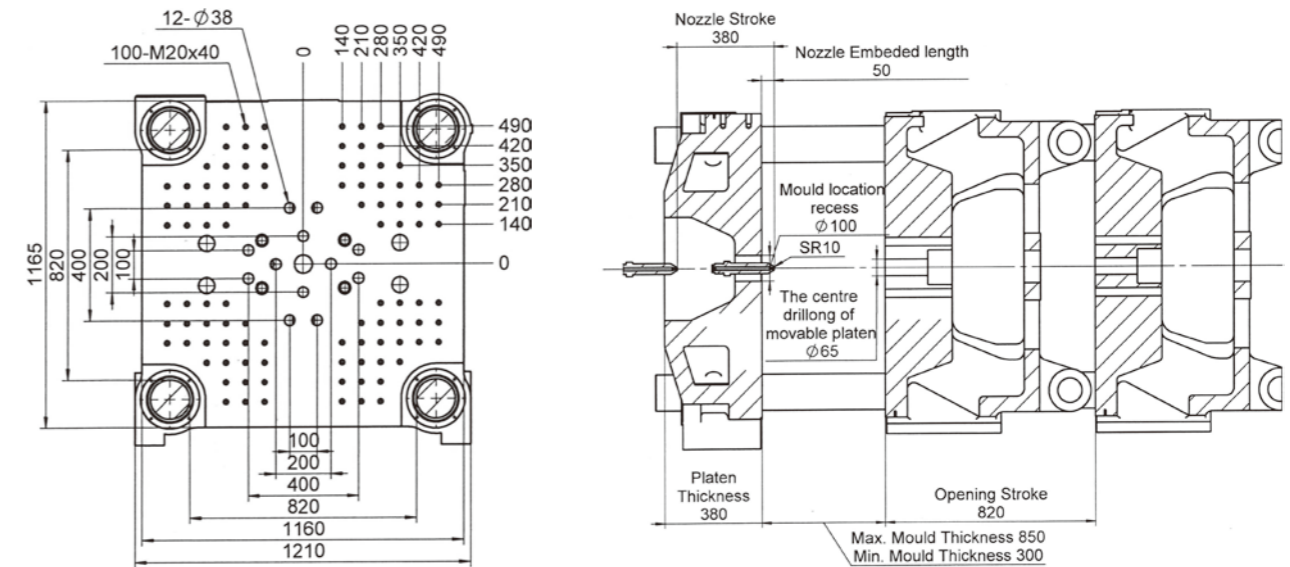

INJECTION UNIT		A	B	CLAMPING UNIT	
Screw Diameter	mm	52	60	Clamping Force (Max.)	ton 470
Screw L/D Ratio	L/D	26	26	Opening Stroke	mm 820
Screw Stroke	mm	260		Space Between Tie Bar(H*V)	mm 820x820
Swept Volume	cm <sup>3</sup>	552	735	Mould Thickness(Min-Max)	mm 300-850
Shot Weight (PS)	g	502	669	Ejector Force	ton 16.6
Shot Weight (PS)	oz	17.7	23.6	Ejector Stroke	mm 200
Injection Pressure (Max.)	kgf/cm <sup>2</sup>	1631	1225	Mould Register Hole	mm 100
Injection Rate	cm <sup>3</sup> /s	869	1111	POWER/HEATING UNIT	
Injection Speed (Max.)	mm/s	500		System Pressure	kgf/cm <sup>2</sup> 175
Screw Rotation Speed (Max.)	rpm	300		Motor Power	kW 51+40
Screw Nozzle Force	ton	6.2		Electrical Heating Power	kW 25.05
Nozzle Stroke	mm	380		Barrel Heating Zones	4+1
OTHERS					
Machine Dimensions	m	8.78x2.03x2.10			
Oil Tank Capacity	L	850			
Machine Weight (Approx)	ton	18.5			

# SPEED-PACK II 570

## Specifications

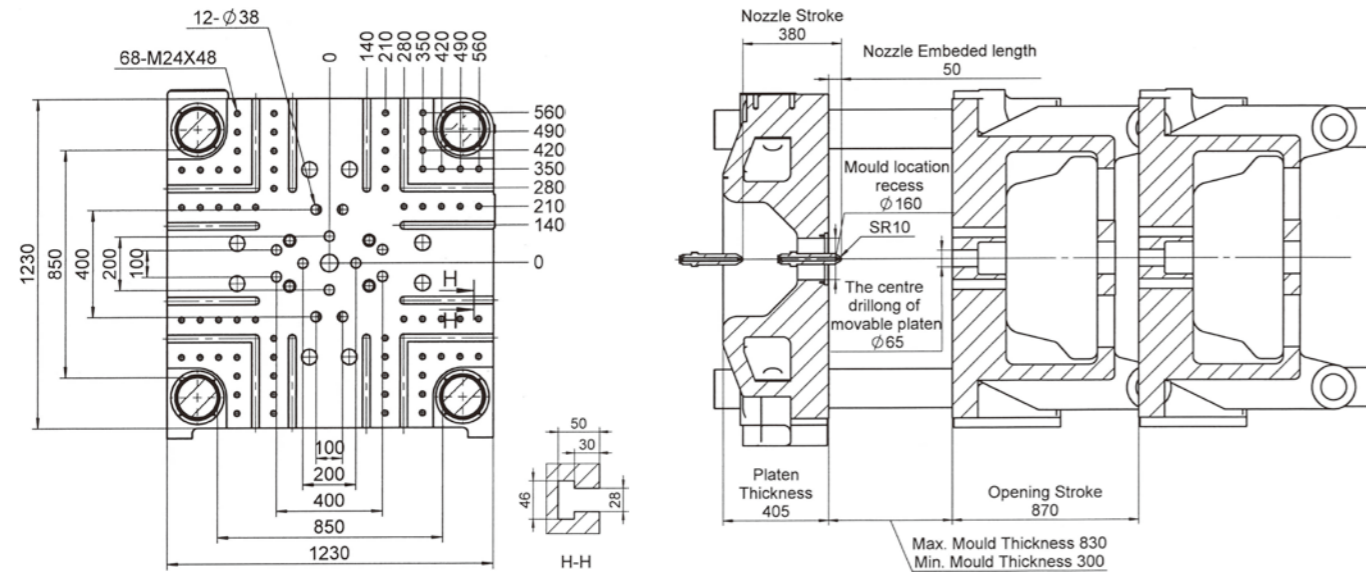

INJECTION UNIT		A	B	CLAMPING UNIT	
Screw Diameter	mm	52	60	Clamping Force (Max.)	ton
Screw L/D Ratio	L/D	26	26	Opening Stroke	mm
Screw Stroke	mm	260		Space Between Tie Bar(H*V)	mm
Swept Volume	cm <sup>3</sup>	552	735	Mould Thickness(Min-Max)	mm
Shot Weight (PS)	g	502	669	Ejector Force	ton
Shot Weight (PS)	oz	17.7	23.6	Ejector Stroke	mm
Injection Pressure (Max.)	kgf/cm <sup>2</sup>	1631	1225	Mould Register Hole	mm
Injection Rate	cm <sup>3</sup> /s	1316	1752	<b>POWER/HEATING UNIT</b>	
Injection Speed (Max.)	mm/s	500		System Pressure	kgf/cm <sup>2</sup>
Screw Rotation Speed (Max.)	rpm	300		Motor Power	kW
Screw Nozzle Force	ton	6.2		Electrical Heating Power	kW
Nozzle Stroke	mm	380		Barrel Heating Zones	4+1

### OTHERS

Machine Dimensions	m	8.94x1.90x1.98	
Oil Tank Capacity	L	850	
Machine Weight (Approx)	ton	22.5	

# T-slots with mounting holes (Optional)

## SPEED-PACK II 260

## SPEED-PACK II 330

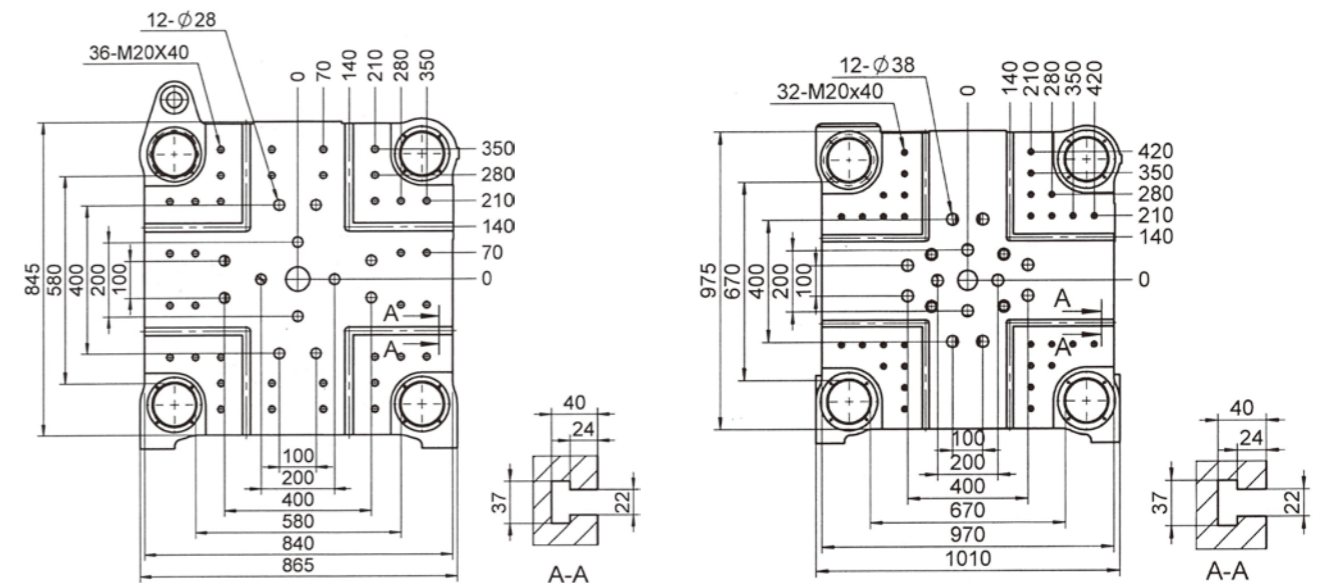

## SPEED-PACK II 400

## SPEED-PACK II 470

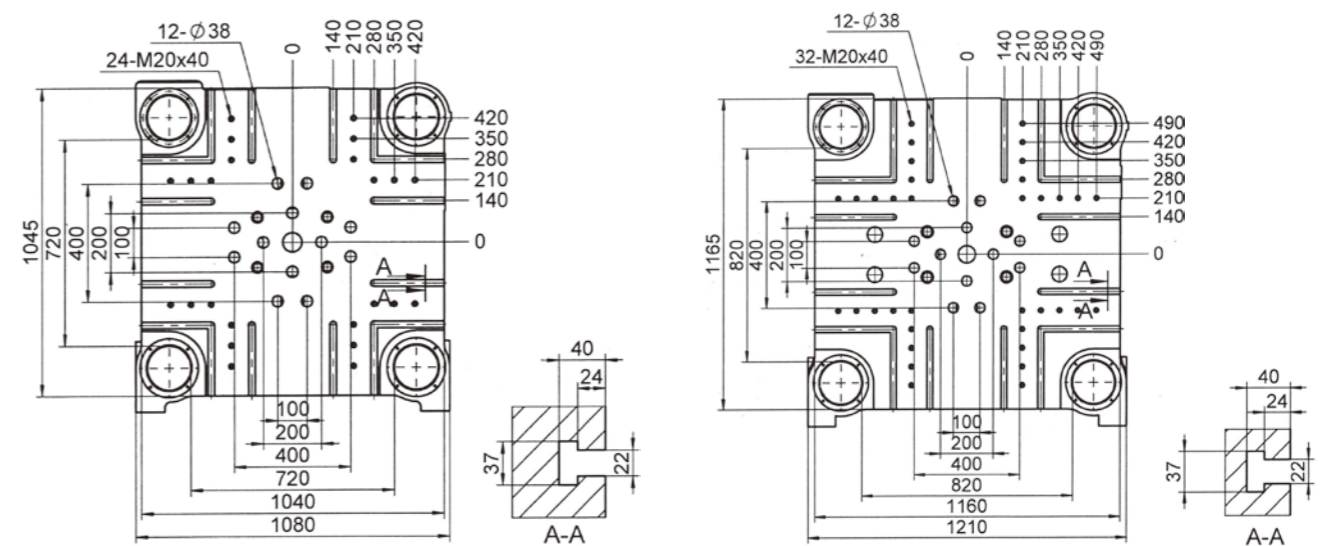

\*The above technical parameters are for reference only, and there may be deviations under different circumstances. The company continues to improve production, so it reserves the right to change product specifications and parameters without prior notice. The final interpretation of this specification sheet is governed by the company.

## A machine fit for most applications

Most industries... and all your needs.



Thin-Walled Packaging



Produce the full range of thin-walled packaging products efficiently and effectively, with turnkey projects.



High-Glass Consumer Products



Easily produce high-gloss automotive, appliances, 3C and 5G parts with strict surface quality specs and no post treatment step.



Medical Consumables



Clean, efficient and highly stable, complete solution to produce the full range of medical consumables, including syringes, drippers, petri dishes and other disposable medical supplies.

## Standard features

- |   |   |
|---|---|
| 1. Advanced intelligent controller system with 10" display      | 2. Servo-system with high dynamic responses                 |
| 3. High-response hydraulic components                           | 4. Specialty screw tailor-designed for high-speed packaging |
| 5. Ceramic heater bands   | 6. Low-friction nozzle design                               |
| 7. High-response non-contact potentiometers                     | 8. 4-6 sets of air blows                                    |
| 9. 1 set of hot runner/valve gate control interface             | 10. Robot interface   |
| 11. 12/24-in, 12/24-out water manifold with D10 fast connectors | 12. High-efficiency by-pass oil filter                      |
| 13. Ergonomic guard doors height                                | 14. Effective over-sized hi-mounts                          |
| 15. Enlarged, high-efficiency oil cooler                        | 16. 3-color signal light                                    |

## Optional Features

- |  |   |
|--|---|
| 1. Advanced intelligent controller system with 15" large display | 2. Custom nozzle designs                                |
| 3. Pneumatic/hydraulic shut-off nozzle                           | 4. Closed-loop lubrication system                       |
| 5. 6-12 sets of air blows  | 6. 2-20 sets of hot runner/valve gate control interface |
| 7. 1-60 sets of hot runner/valve gate control interface          | 8. Core-pull-on-fly                                     |
| 9. Recovery-on-fly   | 10. Infrared barrel heating system                      |
| 11. Induction barrel heating system                              | 12. Barrel insulation cover                             |
| 13. EUROMAP 12 robot interface with connectors                   | 14. EUROMAP 67 robot interface with connectors          |
| 15. Enhanced Stability Control Pack                              | 16. Stepped-style adjustable mould clamps               |