

MK6.6 Euroseries

88 - 658 ton

202207



CHEN HSONG

Address: Hooghe Weg 4, 47906 Kempen, Germany

Phone: +49(0)15204695827

Email: europe@chensong.com

Website: chensong.com

About Chen Hsong

Chen Hsong, established in 1958, is one of the largest manufacturers of injection moulding machines in the world, with annual sales exceeding 20,000 sets.

For over 60 years, Chen Hsong sold to more than 85 countries across the globe, supplying injection moulding machines with clamping force from 20 tons to 6,500 tons. In 1991, Chen Hsong became listed on the Hong Kong Stock Exchange (stock code: 00057). Headquartered in Hong Kong, Chen Hsong operates numerous manufacturing and research facilities in China, including Shenzhen, Shunde, Ningbo and Taiwan, as well as in Japan.

Since 2011 when Chen Hsong and Mitsubishi Plastics Technology of Japan entered into a worldwide strategic partnership, Chen Hsong has been progressively upgrading its internal management, production and quality systems with industry best practices, including TPS (lean manufacturing), M-System (Mitsubishi quality system) and a Japanese “perfect quality” focus towards all R&D, procurement and production activities. For over a decade since then, and leveraging its superior supply chain and production capabilities, Chen Hsong also supplied Mitsubishi, as OEM, with world-renowned “MMX” large-tonnage two-platen injection moulding machines (up to 3,500 tons).

To provide customers with even better peace-of-mind, Chen Hsong insists on being the only fully vertically-integrated maker of injection moulding machines globally, starting from basic ductile iron casting to high-end fabrication and machining, and all major production steps until the completed assembly of each machine. Only through absolute control of each fine step of the manufacturing process would customers be best served with professionalism, quality and perfection.

60+ Years of Excellence
Since 1958

200+ Patented technologies



















20+ Software IP

20,000 Sets / year
One of the largest producers of injection moulding machines in the world

Operates **800,000m²**
Production facilities with global presence

Wide Adaptability – A Machine for All Seasons

Perfect for all applications in diverse industries, meets all needs

 Automotive		
 Electronics		
 Medical Consumables		
 Optics		
 Toys		
 Home Appliances		

MK6.6 Euroseries



Brain of the machine – superiority guaranteed

B&R9 SmartMold 9 professional controller – power and ergonomics perfected



Advanced toggle design from decades of experience

Optimised motion control profile guarantees high speed with high stability

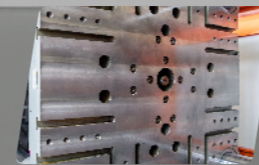

High-strength platens ensure high-quality precision parts

Patented high-strength platens have low deformation

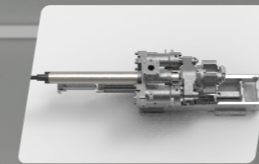

Perfect parts from high-precision injection unit

Linear guide rails for injection - highly stable, high precision, high repeatability



Break-Away Performance Speaks for Itself

Application Cases

Part Specifications

LED lighting part
 Shot Weight : 121g
 Cavities : 8
 Resin : PC
 Cycle Time : 32.4s

Mould
 Weight : 350kg
 Dimensions : 400mmx400mmx300mm



Production data for LED lighting part

Part Weight Distribution

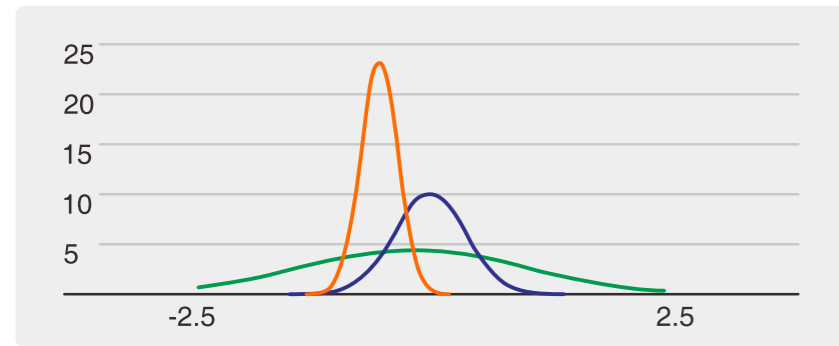

Part Weight CPK Comparison

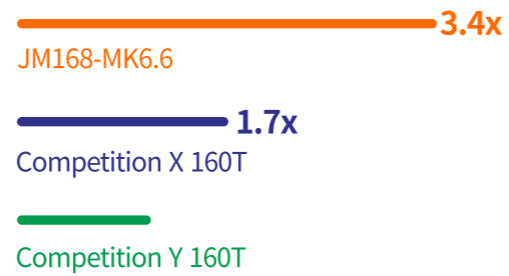

Wall Thickness Distribution

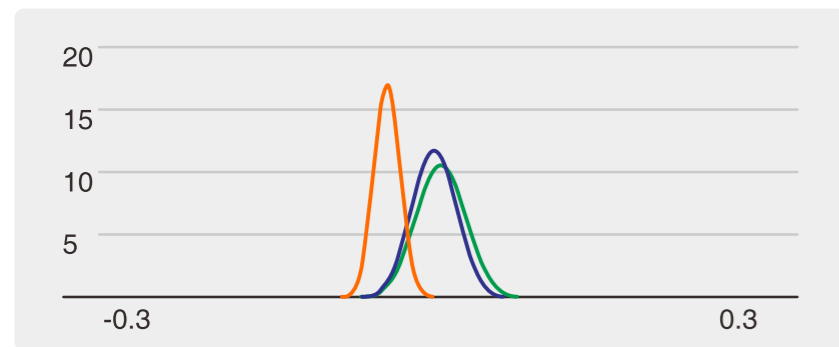

Wall Thickness CPK Comparison

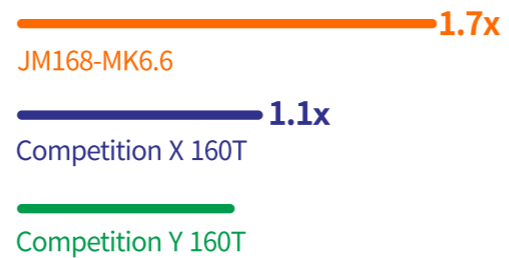

JM168-MK6.6 Competition X 160T Competition Y 160T

CPK (Process Capability Index) – higher is better, indicating higher stability and quality.

Breaks No Sweat – Sustainable Productivity

Clamp Open Position Distribution

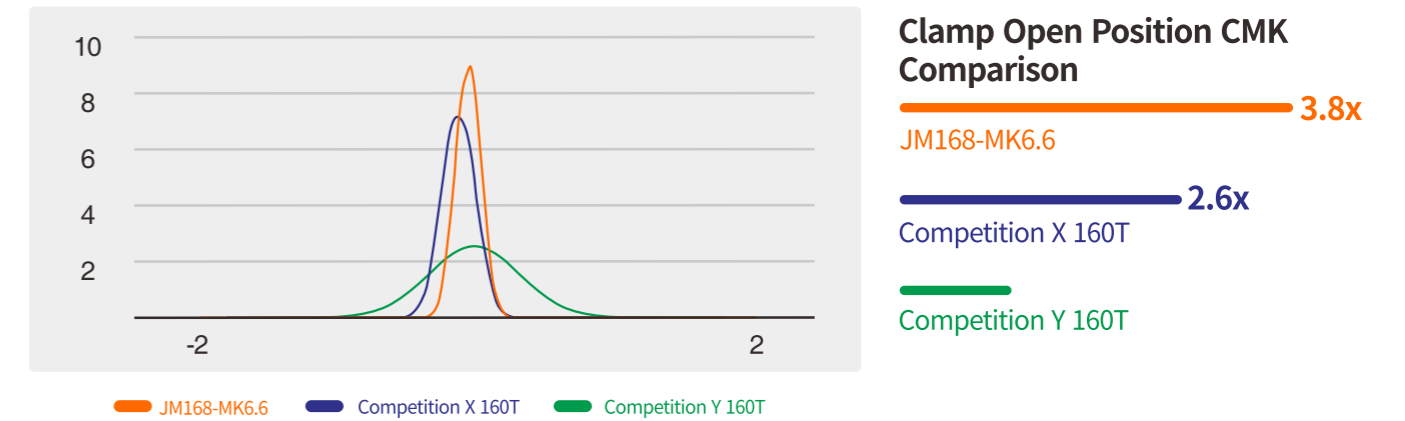

CMK (Machine Capability Index) – higher is better, indicating higher repeatability and better control

How Fast Is Fast Enough

Dry Cycle Comparison

Average (s)	Clamp Close (s)	Clamp Open (s)	Total Cycle (s)	Stroke (mm)
JM168-MK6.6	1.18	1.06	2.24	300
Competition X 160T	1.26	1.19	2.45	300
Competition Y 160T	1.33	1.25	2.58	300

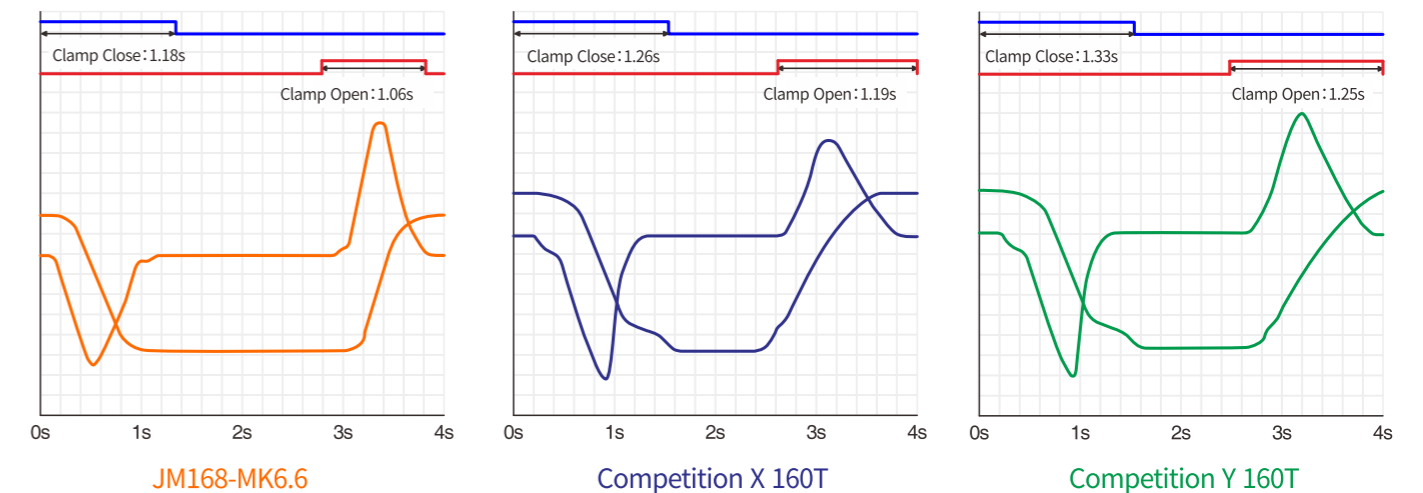

13% Faster Dry Cycle **15% More Speed**

The Economics of Production

How productivity and energy saving translate into real profits

Power consumption comparison (against industry average for 160T)

Application Case Example : LED lighting part

Model	Cycle Time (s)	Production Time (h)	Power Consumption (kW · h)	Total Number of Cycles	Total Product Weight (g)	Average Power Consumption per Kg (kW · h/kg)	Average Power Consumption per Cycle (kW · h/Cycle)
JM168-MK6.6	32.4	8	50.4	889	107556	0.469	0.0567
Industry average for 160T	35.7	8	57.6	807	98420	0.585	0.0714

Show Me The Numbers

Production Simulation

11M

11 months of production per year

21H

21 hours of production per day

€0.25

€ 0.17~0.35/kW · h

10Y

10 years of primary usage

Faster is always better

JM168-MK6.6 produces more shots in 10 years

$(889-807) \times 3 \times 21 / 24 \times 30 \times 11 \times 10 =$

710,325 more shots

Efficiency is the name of the game

JM168-MK6.6 produces 8 million shots in 10 years, saving about €29,400 in energy costs

$(0.0714-0.0567) \times 8,000,000 \times 0.25 =$

€29,400

9% higher productivity

Toggle Design from Decades of Experience

Optimised motion control profile guarantees high speed with high stability

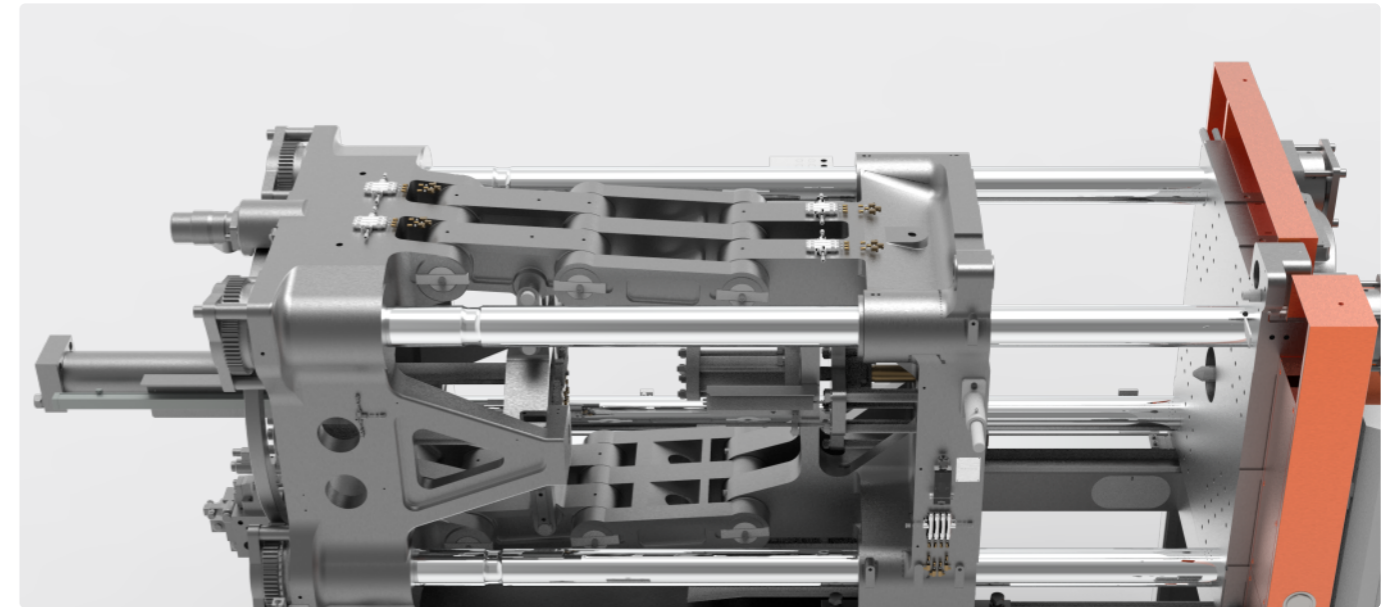

Professional Japanese mechanical experts took the latest and newest in toggle design and hand-fitted a motion-control profile based on large amounts of software simulation and real-life verification. This combination largely avoids unnecessary friction and shocks among mechanical components, distributes tension uniformly to all tie-bars, and ensures high degree of parallelism, in order to prevent flashes on parts and reduce toggle wear. The result is a toggle system that moves snappily, silky-smooth and with no vibrations, improving power efficiency and usage life while protecting against mould damages and unscheduled downtime.

Perfect Union of Toggle Design and Hydraulics

Fast and Precise

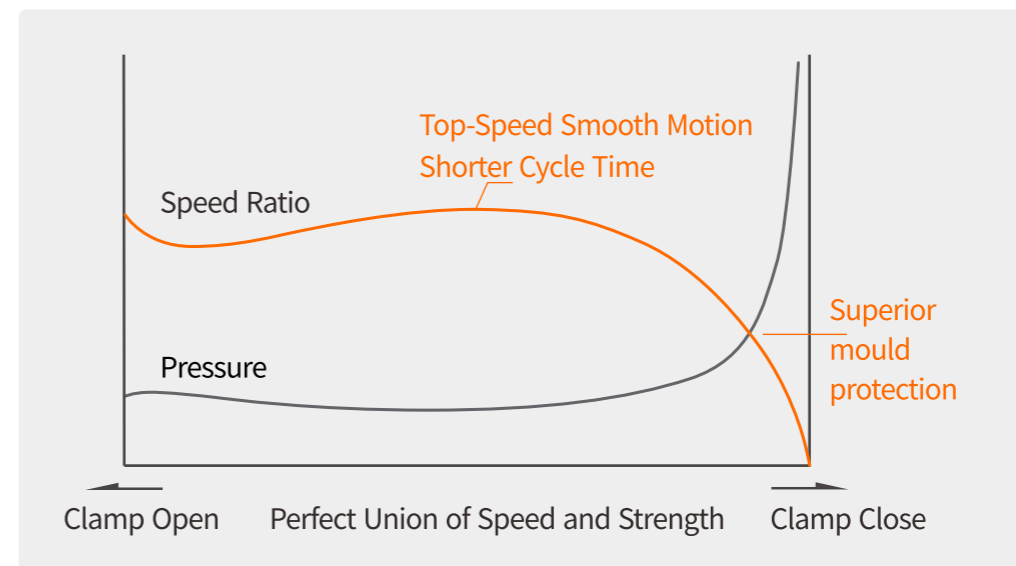

Finely tuned by leading Japanese hydraulic experts, and enhanced via proprietary fluid-dynamics simulation software, the entire hydraulic circuit is optimised to a high degree of perfection.

Strong Platens for High Quality Parts

Patented high-strength platens with low deformation

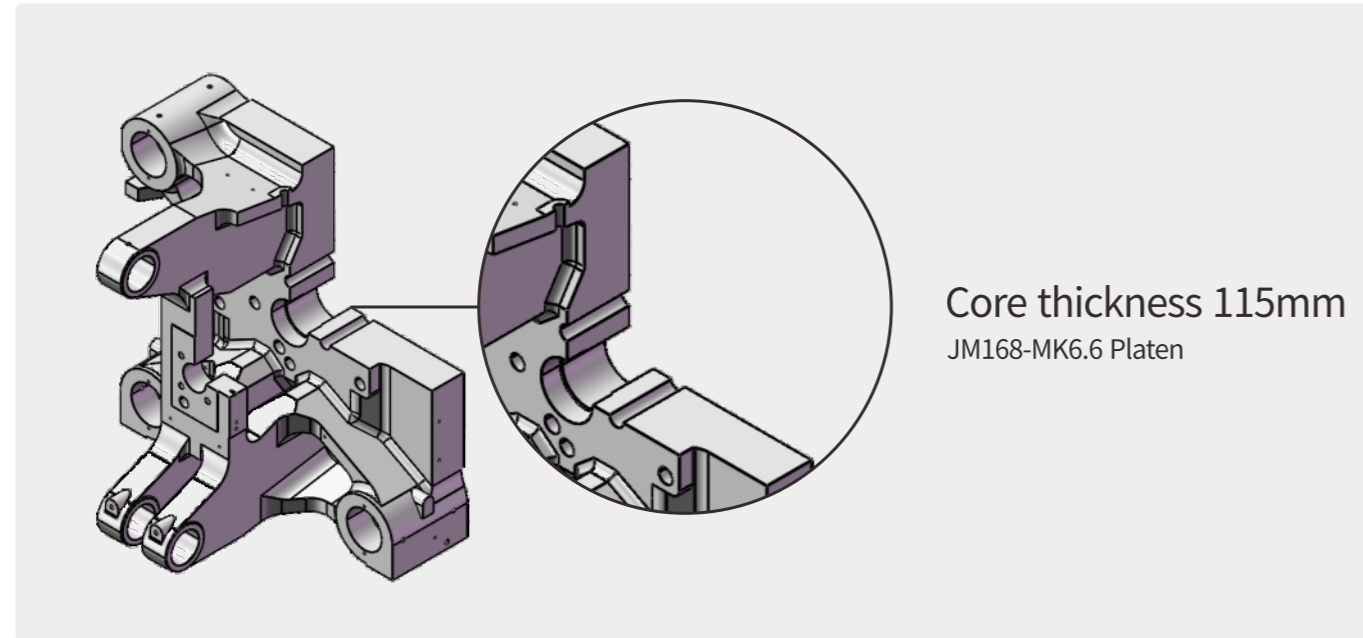

The centre of both platens is thickened to achieve lower deformation, and thus more uniform clamping force on the mould, than most competitive offerings.

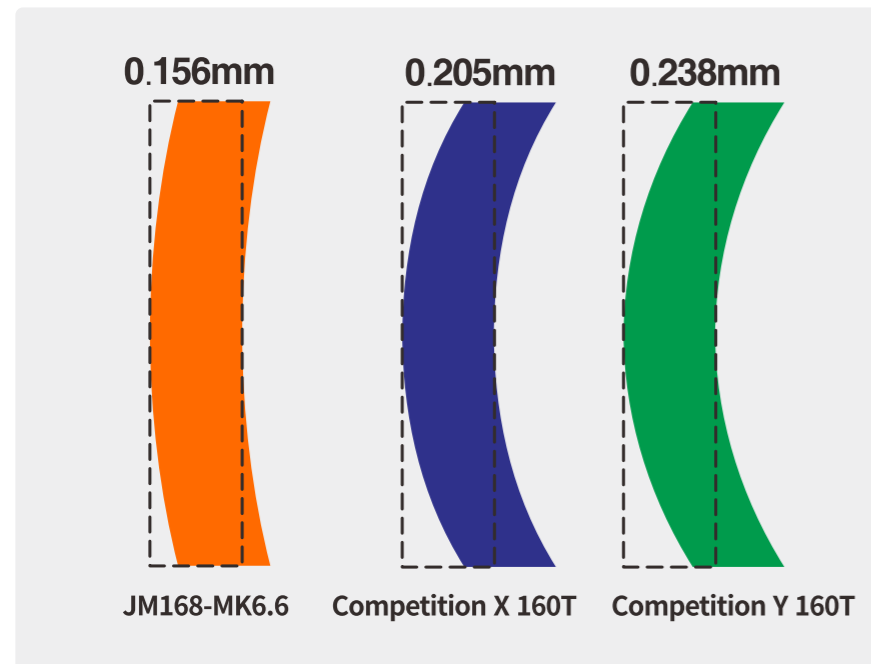

Low platen deformation ensures high part quality and superior mould protection

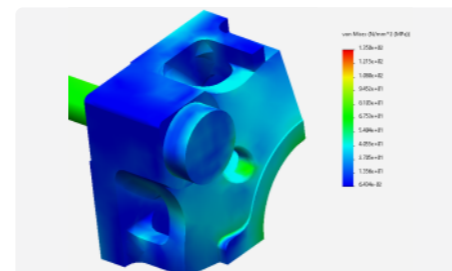

Optimised platen design has superior stress distribution, ensuring perfect part quality

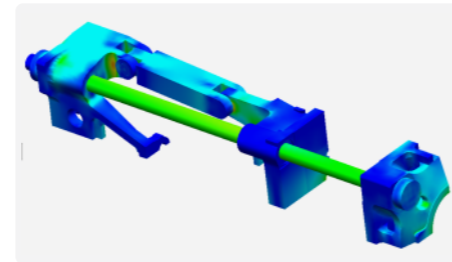

High-tensile tie-bars

Linear Guide Rails for Stable Injection

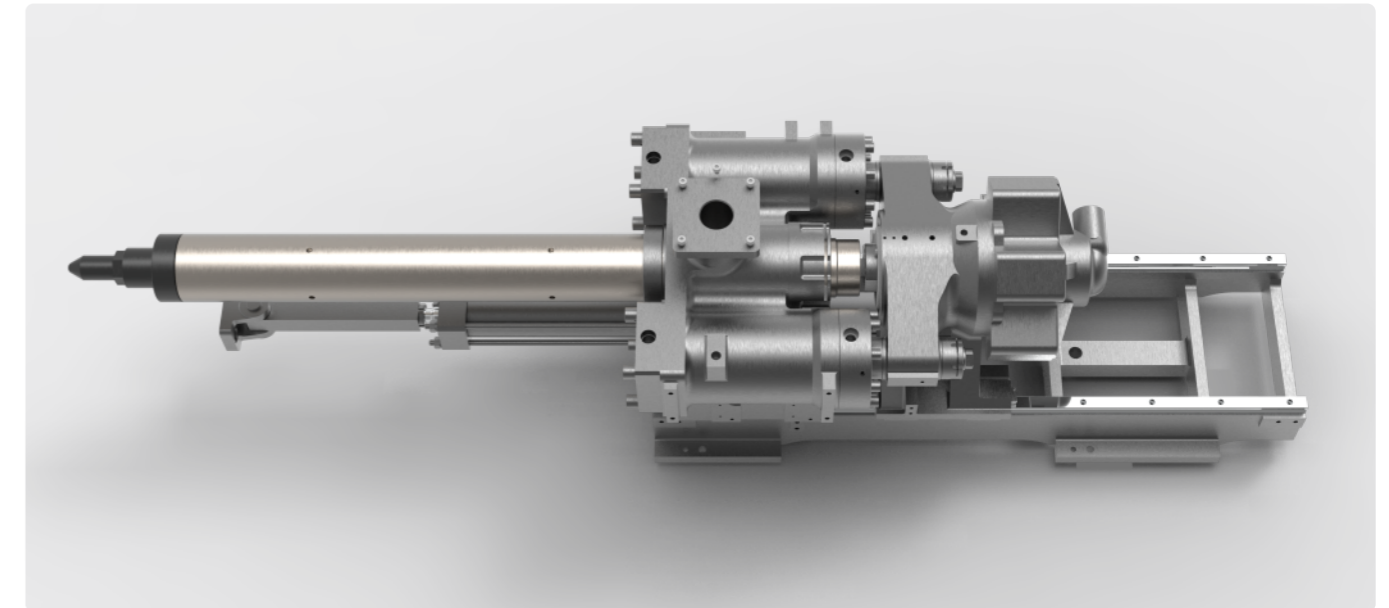

High Accuracy - Low-friction linear guide rails ensure silky-smooth, highly repeatable injection curves.

High Speed - Inject at high speeds without sacrificing precision, that's a guarantee.

Brain of the Machine – Superiority Guaranteed

B&R Smartmold 9 professional controller
Power and ergonomics perfected



The B&R SmartMold 9 controller offers an integrated solution for the automation of the Chen Hsong injection moulding machines. High-speed applications and complete production cells can be implemented with B&R. The integrated Extremely Fast Control technology enables the sampling of rapidly changing input signals, allowing the injection process to be controlled with high precision. The 10.4" screen area enables a clear process visualization.

Beckhoff X-Mold Controller



Standard Features

Clamping unit

- 1 Automatic mould height adjust
- 2 Hydraulic safety device
- 3 2 core pullers on moving platen
- 4 2 airblows on moving platen
- 5 Euromap 2 platen design *
- 6 Euromap 13 for core and ejector
- 7 Euromap 18 for robot mounting
- 8 Euromap 67 for robot communication
- 9 Automatic toggle lubrication
- 10 Anti-skid plates on horizontal surfaces

INJECTION UNIT

- 1 Ceramic heater bands
- 2 Nitride screw and barrel
- 3 Back pressure control
- 4 Linear transducer on injection stroke
- 5 Linear transducer on injection unit stroke
- 6 Screw speed indicator
- 7 Controlled barrel cooling
- 8 Central lubrication points
- 9 Anti-skid plates on horizontal surfaces
- 10 (Locking type) Screw tip set (488T or above)

OTHERS

- 1 Power sockets 3-phase 400V 32A and 16A
- 2 2 Power sockets 2-phase 240V 16A
- 3 6 Waterflow regulators (more available upon request)

Optional Features

Clamping unit

- 1 Additional corepullers (up to 6 core pullers)
- 2 Additional airblow on moving platen
- 3 Parallel core movement
- 4 Parallel ejector movement
- 5 Euromap 70 and 70.1
- 6 Larger maximum mould height
- 7 Automatic lubrication on mould height adjust

INJECTION UNIT

- 1 Bi-metallic screw and barrel
- 2 PET or PVC screw features
- 3 Barrel shut-off nozzle
- 4 Hydraulic/pneumatic sequential injection (up to 12 valves)
- 5 Barrel insulation
- 6 Parallel plasticizing
- 7 (Locking type) Screw tip set (88T-480T)

CONTROLLER

- 1 Beckhoff X-Mold Controller

OTHERS

- 1 Up to 16 zones integrated hotrunner System (Euromap 14 standard)

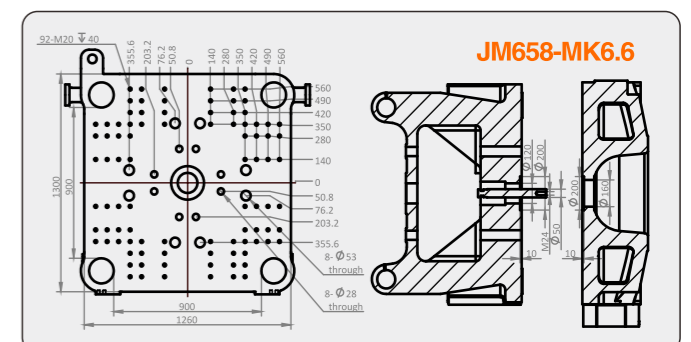
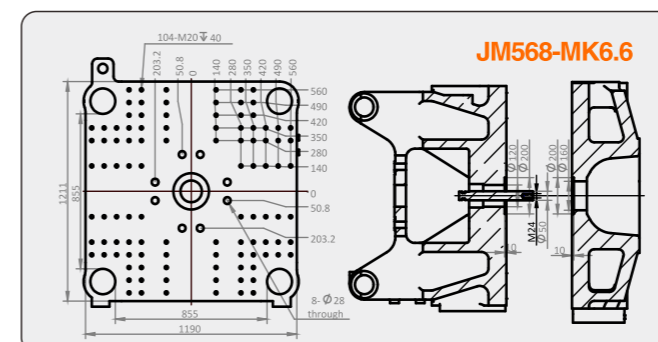
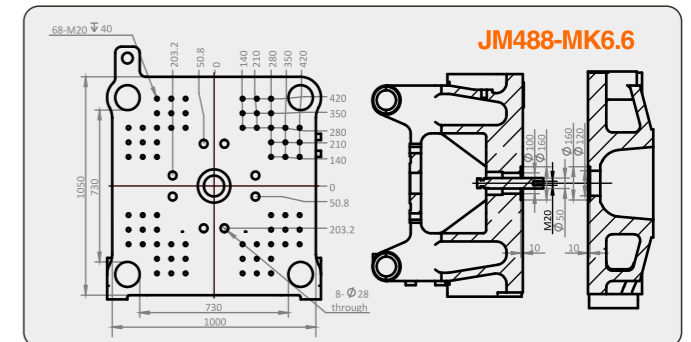
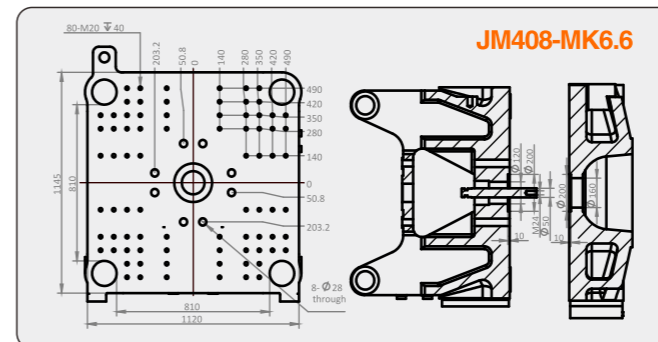
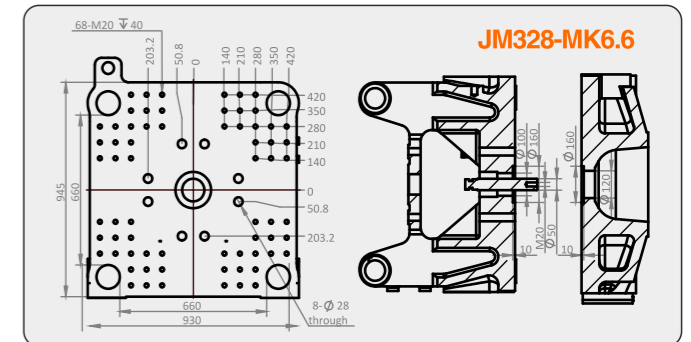
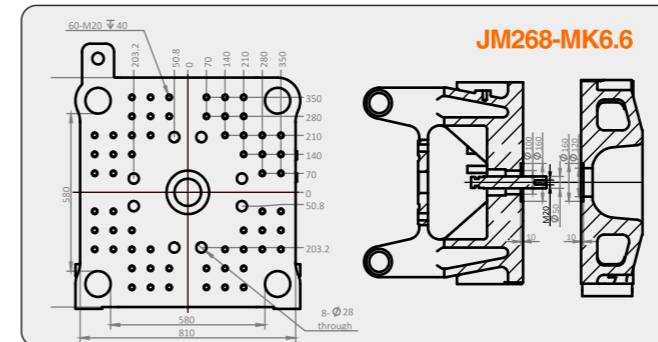
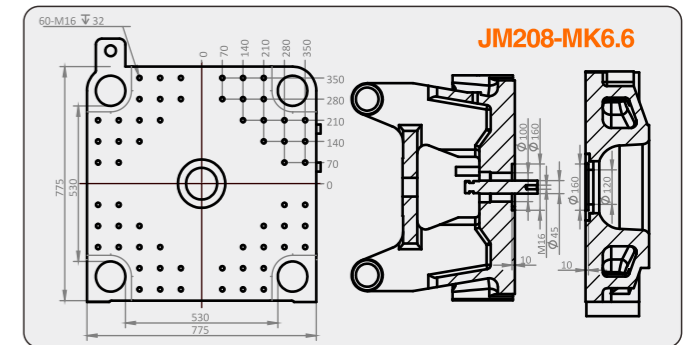
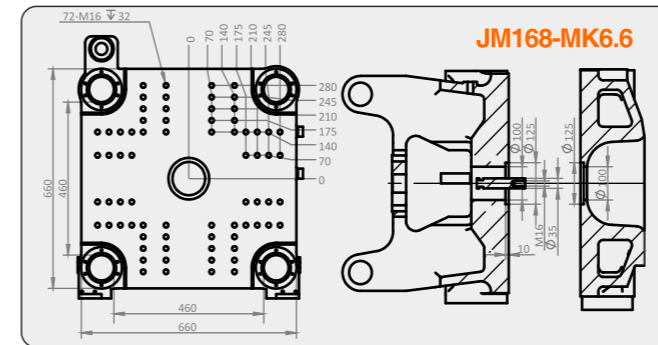
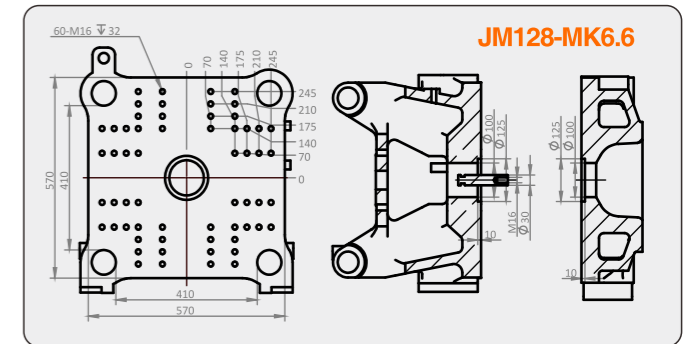
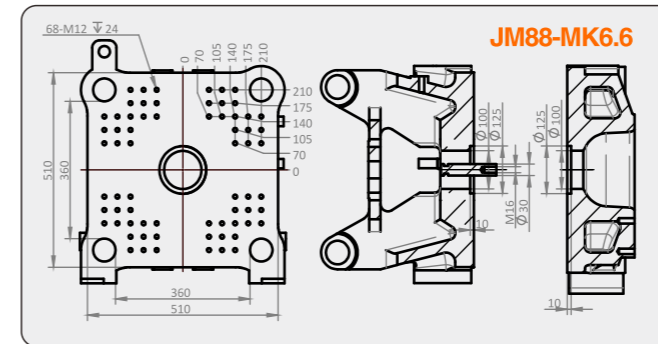

JETMASTER MK6.6 Euroseries		JM88-MK6.6			JM128-MK6.6			JM168-MK6.6			JM208-MK6.6			JM268-MK6.6			JM328-MK6.6			JM408-MK6.6			JM488-MK6.6			JM568-MK6.6			JM658-MK6.6		
Injection unit																															
Screw Diameter	mm	31	36	41	36	41	46	41	46	52	46	52	60	52	60	67	60	67	75	67	75	83	75	83	90	75	83	90	83	90	98
Screw L/D Ratio	L/D	24.4	21.0	18.4	23.9	21.0	18.7	23.6	21.0	18.6	23.7	21.0	18.2	24.2	21.0	18.8	23.5	21.0	18.8	23.5	21.0	19.0	23.2	21.0	19.4	23.2	21.0	19.4	23.9	22.0	20.2
Screw Stroke	mm	180			205			230			260			300			335			375			415			415			450		
Swept Volume	cm ³	135	183	237	208	270	340	303	382	488	431	551	734	636	847	1057	946	1180	1479	1321	1655	2027	1832	2244	2638	1832	2244	2638	2433	2861	3392
Injection Weight (PS)	g	123	166	216	189	246	309	276	347	444	393	502	668	579	771	962	861	1074	1346	1202	1506	1845	1667	2042	2401	1667	2042	2401	2214	2603	3087
	oz	4.4	5.9	7.6	6.7	8.7	10.9	9.7	12.3	15.7	13.9	17.7	23.6	20.4	27.2	33.9	30.4	37.9	47.5	42.4	53.2	65.1	58.8	72	84.7	58.8	72	84.7	78.1	91.8	108.9
Injection Pressure (Max)	kgf/cm ²	2367	1755	1353	2302	1775	1410	2233	1774	1388	2295	1796	1349	2365	1777	1425	2263	1815	1448	2230	1780	1453	2165	1765	1504	2165	1768	1504	2114	1798	1516
Injection Rate	cm ³ /s	76	103	133	98	128	161	127	160	204	155	199	265	192	255	318	251	313	392	318	399	488	419	514	604	419	514	604	483	568	674
Screw Rotation Speed (Max)	rpm	207			225			220			180			183			190			178			190			190			175		
Nozzle Contact Force (Max)	t	4.5			4.5			4.5			4.5			9.0			9.0			9.0			9.0			9.0			9.0		
Nozzle Stroke	mm	250			250			250			280			330			360			420			420			420			460		
Clamping unit																															
Clamping Force (Max)	t	88			128			168			208			268			328			408			488			568			658		
Opening Stroke	mm	330			370			420			490			530			600			670			770			835			920		
Space Between Tie Bars (HxV)	mm	360x360			410x410			460x460			530x530			580x580			660x660			730x730			810x810			855x855			900x900		
Max.Mould Thickness	mm	380			450			520			550			610			660			730			810			850			900		
Min. Mould Thickness	mm	130			145			160			180			195			220			250			275			330			350		
Max.Daylight	mm	710			820			940			1040			1140			1260			1400			1580			1685			1820		
Ejector Force	t	2.8			4.2			4.2			6.7			7.7			7.7			11.1			11.1			16.6			18.2		
Ejector Stroke	mm	100			120			140			150			170			170			220			220			250			265		
Centre Ring Diameter	mm	125			125			125			160			160			160			160			200			200			200		
Others																															
System Pressure	Mpa	17.5			17.5			17.5			17.5			17.5			17.5			17.5			17.5			17.5			17.5		
Pump Motor	KW	11			15.7			15.7			24			31			48			60			62			62			79		
Electrical Heating	KW	6.9			10.5			12.9			16.2			19.7			25.7			31.2			36.8			36.8			44.2		
Temperature Control Zones	Zones	3+1			3+1			3+1			3+1			4+1			4+1			5+1			5+1			5+1			6+1		
Machine Dimensions (LxWxH)	m	4.6x1.2x1.8			4.9x1.3x1.8			5.5x1.4x1.2			6.0x1.5x2.1			6.7x1.6x2.3			7.2x1.7x2.4			7.8x1.8x2.3			8.6x1.9x2.3			8.9x2x2.3			9.9x2.2x2.5		
Oil Tank Capacity	L	160			190			250			320			410			540			670			800			800			870		
Machine Weight	t	2.9			3.5			4.4			5.8			8			10.2			13.7			17.7			18.9			24.2		

*The technical parameters above are for reference only and discrepancies may arise in different circumstances. The company keeps upgrading the products and reserves the right to change the product specifications and parameters without prior notice. The final interpretation to the above specifications and parameters belongs to the company.